

A GUIDE TO RGB STRIP LIGHT

Use this guide to assist in the design and wiring of a 12V or 24V RGB strip light installation. Although the use of 24V strip allows longer lengths to be run, careful design and wiring is required to eliminate colour shift on the white setting.

Strip Lengths

The length of a continuous section of strip light (strip powered from one end) should be limited to the maximum lengths given in Table 1 below. Longer lengths may result in a pink tint towards the end of the strip when set on white.

Strip Type	Voltage	Max Length
RGB 5050 strip	12V	5m
RGB 5050 strip	24V	8m

Table 1: Absolute maximum single length (based on 0.5m 0.75mm cable)

When longer lengths are required the following options can be used:

- Split the length into two shorter lengths and power them from the middle (or the ends)
- Split the length into multiple shorter lengths and run a power cable alongside the length of strip

Never power a single length of RGB LED strip light that is >8m from one end of the strip. Instead, run two shorter pieces and power them from the middle or from either end.

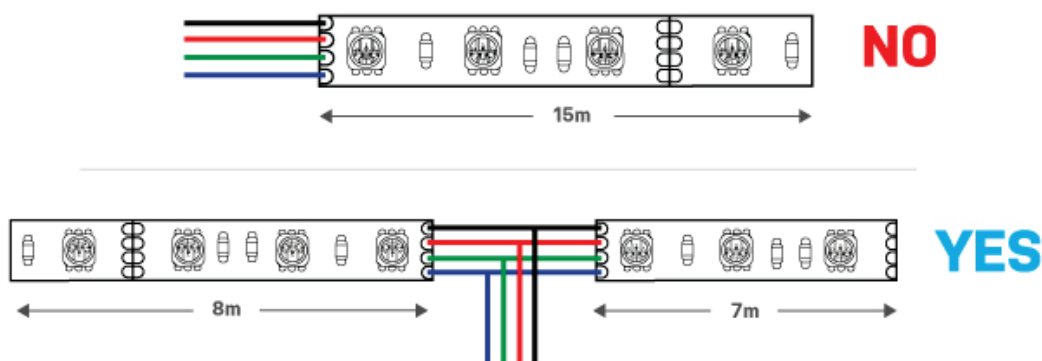

Cable Lengths

When running long cable lengths from the control gear to the strip, the minimum cable size depends on both the length of cable and the total length of strip (power draw). Use the following formula to calculate the cable size Cross Sectional Area in mm²:

$$CSA_A = 1.3 \times \sqrt{\frac{StripLength_u \times CableLength_l}{Voltage_v}}$$

Where StripLength is the total length of the strip in meters, CableLength is the length of cable in meters, and Voltage is the DC power supply voltage (12 or 24). Some examples are shown in Table 2:

Strip Type	Strip Length	Cable Length	Cable Size
24V RGB	3m	2m	0.65mm (use 0.75mm)
24V RGB	3m	3m	0.80mm (use 1mm)
24V RGB	5m	3m	1.03mm (use 1mm)
24V RGB	8m	3m	1.30mm (use 1.5mm)
24V RGB	10m	3m	1.45mm (use 1.5mm)
24V RGB	5m	8m	1.68mm (use 2.5mm)
24V RGB	7m	8m	1.99mm (use 2.5mm)

Table 2: Calculating cable size

Power Supply

The total power draw of the strip is calculated using the formula below:

$$\text{Power } P = 15 \times \text{Length } L$$

Where Power is the total power and Length is the length in meters. The 5050 RGB strip draws approximately 15W per meter.

The power supply should be selected so the total power draw of the strip does not exceed 90% of the power supply rating. If the power draw is too high for a single power supply, the strip should be split into two or more sections, and each additional section requires an additional power supply and an RGB Amplifier. You can view our available power supplies on our website.

Controllers and Amplifiers

RGB strip is connected via a 4-core wire which contains wires for red, green, blue and a common positive. To control RGB strip, an RGB controller is used. We have a selection of RGB controllers and amplifiers, contact us or visit our website for more information.

Wiring

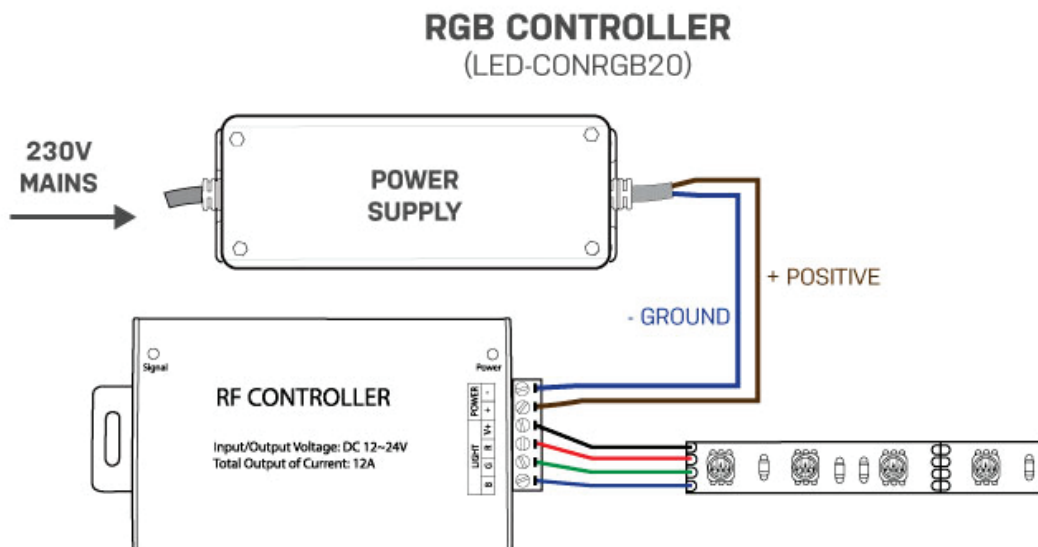

RGB CONTROLLER & AMPLIFIER (LED-CONRGB20 & LED-CONAMP10)

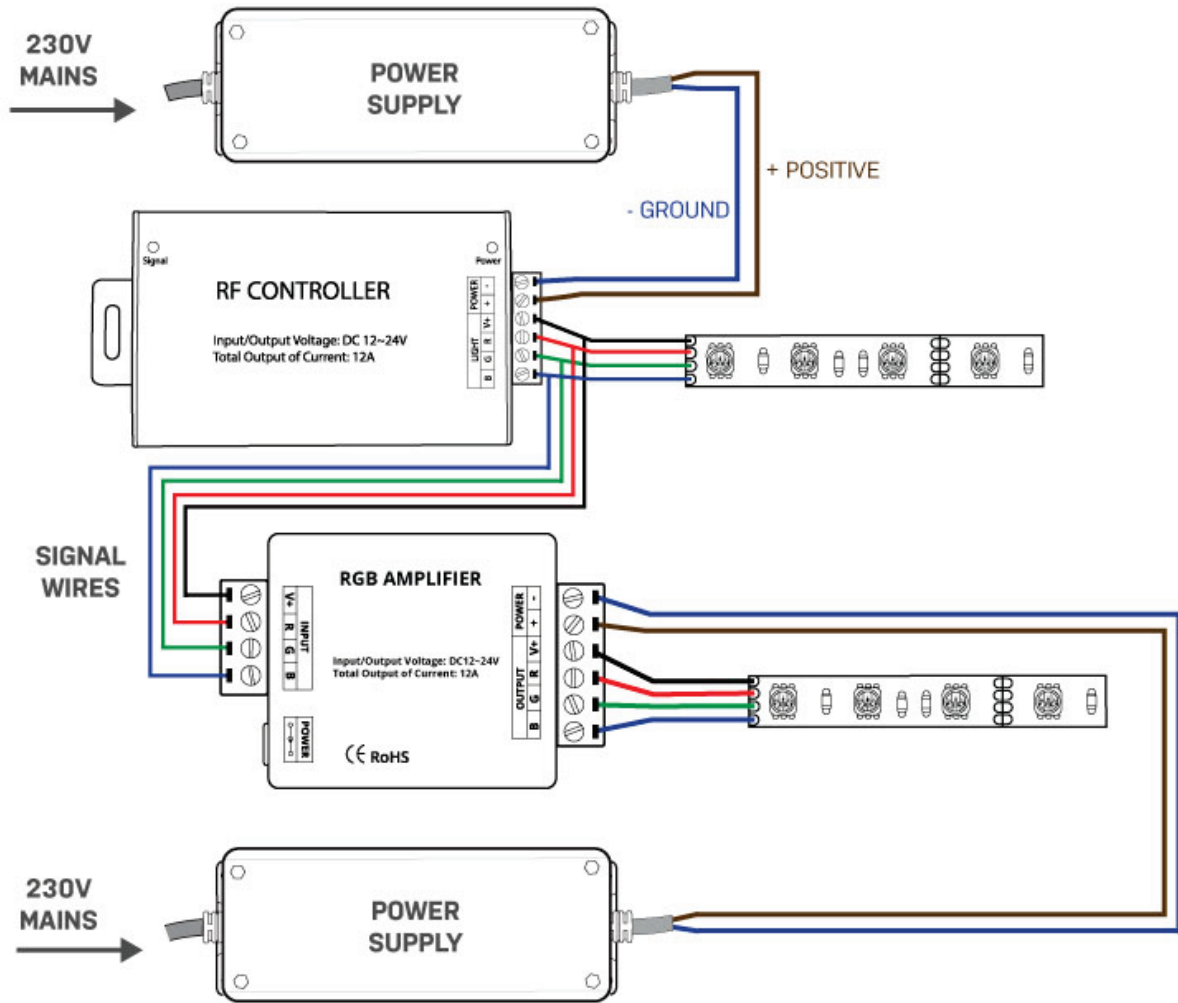

Examples

Example 1: Install 12m of 24V strip light, 4m from the controller

The total power draw is $15 \times 12\text{m} = 180\text{W}$. We can use a single controller, and a single 200W supply.

12m is too long as a single length, so it will be run from a mid-point of 6m and 6m.

The minimum cable size is 1.84mm. Use a 2.5mm cable, or wire the two strips with separate 1.5mm cables.

Example 2: Install 18m of 24V strip light, 3m from the controller:

The total power draw is $15 \times 18\text{m} = 270\text{W}$. We must split it into two sections, each with a 150W supply.

The first section can be wired to any controller, and the second section will be wired to an RGB amplifier.

Each section will be 9m, which is too long as a single length, so each section will have one 4m and one 5m length.

The minimum cable size for each section is 1.38mm. Use a 1.5mm cable for each section.

The first section will run from the RGB controller.

Safety

It is recommended that any electrical work be performed by a registered electrician. If you will be attempting any work yourself, please review the NZECP 51 - Electrical Code of Practice for Homeowners document on the Energy Safety website. Go to www.worksafe.govt.nz and search for "ECP 51".