

LED SPECIFICATION

Part No.: LED-530IR8C

Features:

- Single color
- High Power output
- Low power consumption
- High reliability and long life

Descriptions:

- Dice material: AlGaAs
- Emitting Color: Infrared Emitting diodes
- Device Outline: ϕ 5mm Round Type
- Lens Type: Water Clear

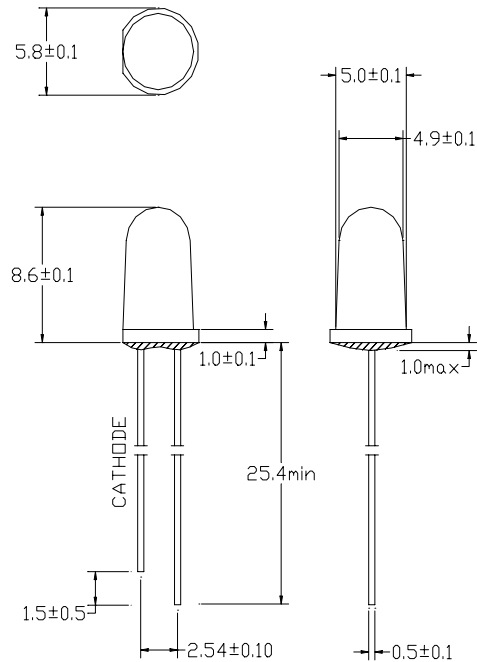

● Tolerance is ± 0.25 mm unless otherwise noted

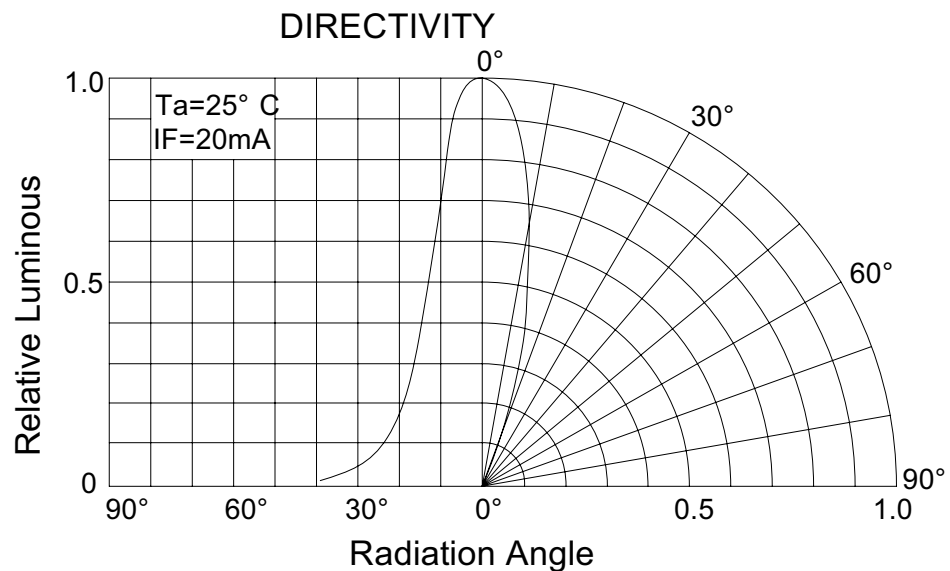

LED SPECIFICATION

Part No.: LED-530IR8C

Absolute maximum ratings (Ta = 25°C)

Parameter	Symbol	Test Conditions	Characteristics		Unit
			Min.	Max.	
Power Dissipation	P_d	—	—	100	mW
Reverse Voltage	V_R	$I_R=10\ \mu\text{A}$	9	—	V
Forward Current	I_{FM}	Duty=0.01mS 1kHz	—	1000	mA
Operating Temperature Range	T_{opr}	—	-25	+75	°C
Storage Temperature Range	T_{str}	—	-40	+100	°C
Soldering Temperature	T_{sd}	$t \leq 5\text{sec}, 2\text{mm from case}$	—	260	°C

Electrical and optical characteristics (Ta = 25°C)

Parameter	Symbol	Test Condition	Value			Unit
			Min.	Typ.	Max.	
Forward Voltage	V_F	$I_F = 50\text{mA}$	----	1.55	1.8	V
Reverse Current	I_R	$V_R = 9\text{V}$	----	----	10	μA
Peak Wavelength	λ_p	$I_F = 50\text{mA}$	----	850	----	nm
Spectrum Width of Half Value	$\Delta\lambda$	$I_F = 50\text{mA}$	—	45	—	nm
Radiant Intensity	I_e	$I_F=50\text{mA}$	—	80	—	mW/Sr
Viewing Angle	$2\theta_{1/2}$	$I_F = 50\text{mA}$	----	30	----	Deg.

LED SPECIFICATION

Part No.: **LED-530IR8C**

Typical electrical/optical characteristic curves:

